



舒乐氏加湿取暖器

HUMIDIFIER HEATER

SLS-JQN1



产品图仅供参考，请以实物为准

使用说明书

感谢您购买本产品！使用产品前请仔细阅读本说明书，并妥善保管。

执行标准：GB 4706.1-2005 GB 4706.23-2007 GB 4343.1-2018 GB 17625.1-2012

Soleus Commercial Consulting (Shanghai) Co., Ltd. (Trademark Holder)

Foshan Fangxin Network Technology Co., Ltd.

After-sales service hotline: 400-8083-081 Official website: www.soleusair.com

Manufacturer's address: No. 304, Floor 3, Building A, No. 12, Lvtian Road, Beiqu Community, Daliang Subdistrict, Shunde District, Foshan, Guangdong Province

感谢惠顾!

- 请在使用前仔细阅读使用说明书,以便正确使用本产品;
- 请妥善保管好本说明书和保修卡,以便以后阅读;
- 产品以包装内实物为准。

目录 Contents

安全注意事项-----	1	保养与清洁-----	7
产品部件名称-----	2	电气原理图-----	8
控制面板-----	3	故障问题与分析-----	9
技术参数-----	4	环保清单-----	10
装箱清单-----	4	保修说明-----	11
功能与操作说明-----	5-6	保修卡-----	12

01 / 安全注意事项

⚠ 使用前须知

第一次使用加湿取暖器时，请先在通风良好的环境下让其连续工作约两小时，以除去发热体表面保护材料的气味。若在第一次使用过程中，产品内部有轻微声响，属正常现象。加湿取暖器在工作时，应保证其所在的环境通风性良好。

- 01、警告：为避免过热，禁止覆盖加热器。
- 02、使用前，请先检查所用电压是否在产品标识的电压相同。
- 03、产品使用时，为避免灼伤，切勿让裸露的皮肤靠近或直接接触出风口表面。
- 04、产品在使用时，电源线应置于机体后面，放到机体前面会使其过热而损坏，甚至发生安全事故。
- 05、严禁与其他大功率电器共用插座，禁止在移动式插座上使用，严禁加长电源线使用。
- 06、严禁直接拉拽电源线来移动产品。
- 07、加热器不得直接置于电源插座下面。
- 08、使用前需要先检查电源线、以及插头是否有破损。
- 09、本产品只适宜室内使用，不宜在室外使用。
- 10、禁止用插拔电源线插头的方法代替开机和关机。
- 11、产品正常使用或闲置时，需离火源或火种1.5米以上，并避免阳光直射。
- 12、禁止在易燃、易爆，受热易变形、变色、变质的物体附近或有严重粉尘的地方使用。
- 13、使用产品时，请先放置平稳，切勿翻倒或倾斜。
- 14、禁止在有易落下悬挂物、易受冲击或摆放不稳定的地方使用。
- 15、在浴缸、喷头或游泳池的周围不得使用本加热器。
- 16、严禁将产品浸入水中。
- 17、严禁用细的金属丝或其它异物插入机内任何孔隙，以免造成触电事故。
- 18、不得利用带有可自动接通电源的程序器、定时器或者其他装置来使用产品。
- 19、若产品出现故障，请立即关机、拔下插头断电，并及时联系售后客服安排维修。非专职人员或者未授权的修理人员，不得自行修理或改装本产品。
- 20、禁止把产品作为动植物的保温、加热设备。
- 21、如果电源软线损坏，为了避免危险，必须由制造商、其维修部或类似部门的专业人员更换。
- 22、新产品第一次开箱使用时可能会有少许异味，属正常现象，将产品放置在通风环境下4小时能大大减轻异味。
- 23、请勿在产品运行中拿掉水箱或直接用手感应水温，以免发生事故。
- 24、切勿在产品顶部放置任何物品或攀爬或坐于本机上。
- 25、清洁产品时，若要取下上盖、水箱等部件，在清洁完后请将其逐一正确安装。若各部件安装不到位可能会影响产品的正常使用。
- 26、每次使用产品前，请把电源线插头完全插入到电源插座，避免插头与插座接触不良而引起异常发热，甚至引发火灾。
- 27、如果产品的发热管玻璃罩出现破损，请立即停止使用本产品，并及时联系售后客服处理。
- 28、在对产品进行清洁或其他维护操作之前，请先关机并拔下电源线插头。
- 29、请勿让儿童、个人行为能力不健全的人士单独操作使用本产品；并且在使用本产品时，切勿让上述人群靠近、接触发热表面，避免发生意外事故。

02 / 产品部件名称

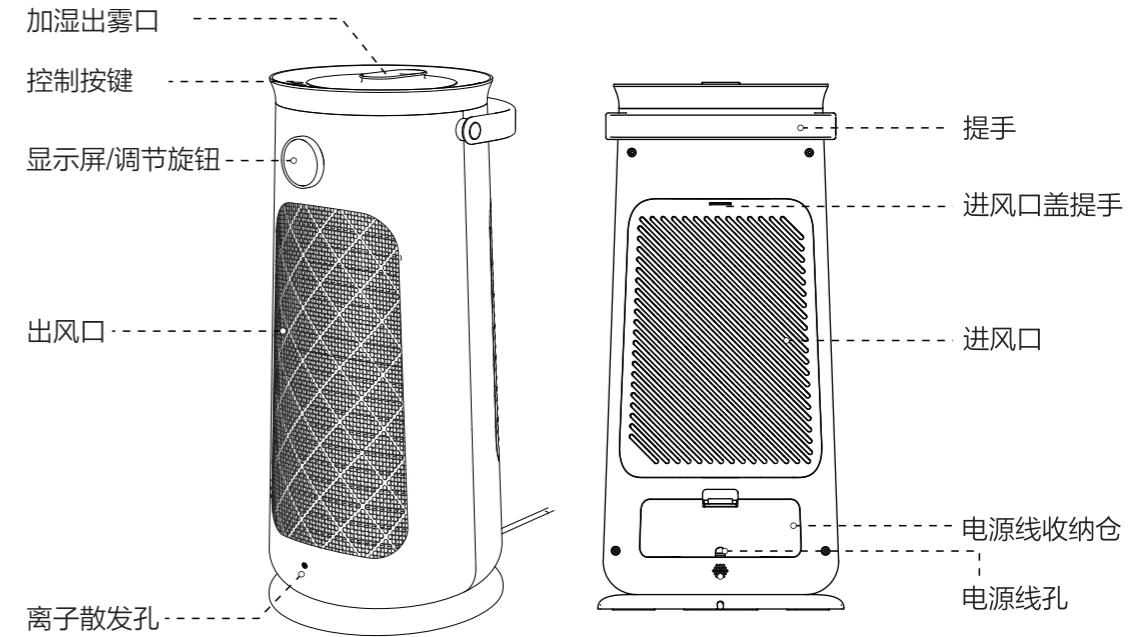

- 由于公司产品不断改进，您所购买的产品可能与说明书图示有所不同，恕不另行通知，请以实物为准。

03 / 控制面板

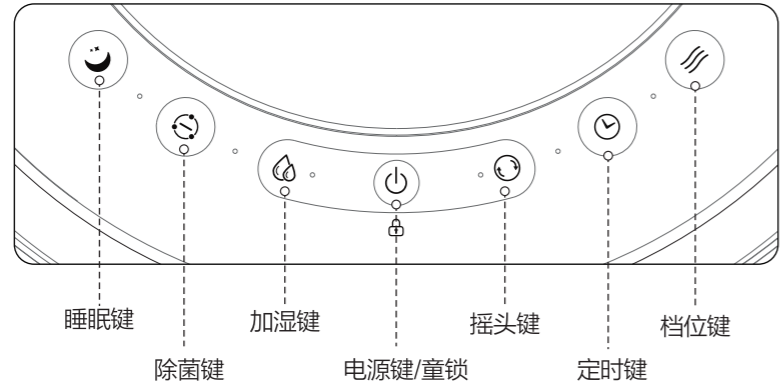

显示界面

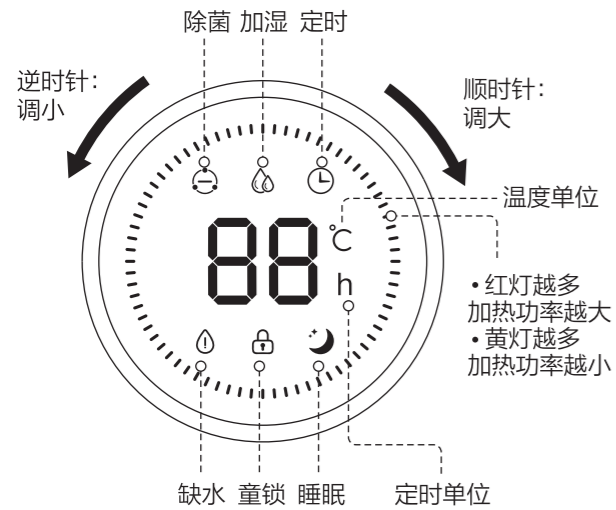

*在P1-P5档位下，转动旋钮，可以调节加热效果。在正常状态下，温度和档位交替显示。

04 / 技术参数

产品名称	加湿取暖器	产品型号	SLS-JQN1
额定电压	220V~	额定功率	2100W
产品尺寸	305x305x654mm	额定频率	50Hz
水箱容量	2.0L	产品净重	7.9kg
执行标准	GB 4706.1-2005 GB 4706.23-2007 GB 4343.1-2018 GB 17625.1-2012		

*以上参数为设计参数，实测参数以产品实物为准。

05 / 装箱清单

序号	部件名称	数量
01	主机	1
02	遥控器	1
03	滤网	1
04	说明书	1
05	遥控器电池（七号电池）	2

*初次使用滤网时，请撕掉薄膜。

遥控器

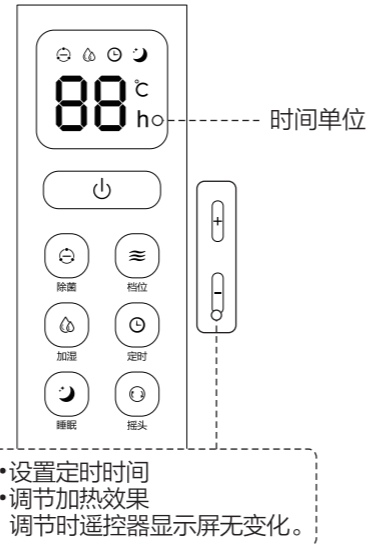

*遥控器的按键操作与机身控制按键功能相同

06 / 功能与操作说明

<p>电源键 /童锁 </p>	<ul style="list-style-type: none"> • 机器通电后，蜂鸣器提示一声，电源键红灯显示，产品进入待机状态。 • 轻触电源键，机器启动，电源键变成白灯显示，默认P0档位。 • 启动运行后，可以按档位键调节到P1-P5档位进行加热取暖，此时可以开启睡眠，除菌，加湿，摇头，定时等功能。 • 启动运行时，轻触电源键，机器停止加热并进入待机状态，风机继续运行一定时间进行散热再停止。再次启动开机，机器会自动恢复到关机前工作设置状态。 • 待机或运行状态，长按电源键，开启童锁，防止误触发启动。 • 童锁状态下，其他按键、旋钮无效，待解锁后操作。 • 童锁状态下，可以使用遥控器进行开/待机再操作。
<p>睡眠键 </p>	<ul style="list-style-type: none"> • 轻触此键，机器进入睡眠模式，默认P1档位工作。 • 睡眠模式下，显示屏会熄灭，仅显示睡眠图标；触摸任意按键，进行唤醒显示，可正常操作。 • 睡眠模式下，可按档位键调节档位或转动旋钮调节加热效果。 • 再次触摸睡眠键，退出睡眠模式。
<p>除菌键 </p>	<ul style="list-style-type: none"> • 轻触此键，开启除菌功能，功能灯点亮。 • 再次轻触此键，关闭除菌功能，功能灯熄灭。
<p>加湿键 </p>	<ul style="list-style-type: none"> • 轻触此键，开启雾化加湿功能，功能灯点亮。 • 再次轻触此键，关闭雾化加湿功能，功能灯熄灭。
<p>摇头键 </p>	<ul style="list-style-type: none"> • 轻触此键，开启摇头功能，功能灯点亮。 • 再次轻触此键，停止摇头功能，功能灯熄灭。
<p>定时键 </p>	<ul style="list-style-type: none"> • 轻触此键，可设置定时关机，转动旋钮或按定时键可设置定时范围0—12h。 • 开启定时关机，功能灯点亮。 • 长按此键，取消定时关机，功能灯熄灭。

功能与操作说明

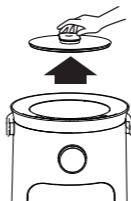
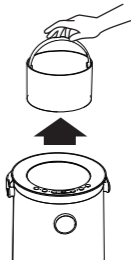
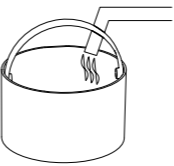
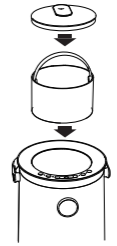
<p>档位键 </p>	<ul style="list-style-type: none"> • 轻触此键，可以循环切换机器P0—P5工作档位。 • P1—P5档位具有不同热风效果，随档位升高逐渐加强取暖效果。 • P0档位不启动热风效果，可配合雾化加湿功能使用。 	<p>调节旋钮或按遥控器上的"+" "-"键</p>	<ul style="list-style-type: none"> • 在不改变机器档位，风速，进行机器微调加热效果。 • 调节时，显示屏外环显示效果会跟随变化。
<p>水箱加水操作</p>  <p>1.关闭机器，拿起机器顶部顶盖；</p>		 <p>2.拿出水箱；</p>	
 <p>3.往水箱里面加适量纯净水； (请使用水温低于40℃的纯净水)</p>		 <p>4.按照顺序组合好水箱和顶盖后，通电并开启加湿功能使用。</p>	

- 加水前，请务必拔掉电源插头；
- 加水请注意，勿将水注到出雾口内；

- 加水高度不得高于最高水位线；
- 请勿在水中加入添加剂，如精油、香水、药物等化学药品。

07 / 保养与清洁

- 1、进行清洁保养前一定要先拔下电源线插头，断开电源，冷却10分钟后，方可进行清洁。
- 2、机身的清洁禁止用水冲洗，可用含少许中性洗涤剂的软布轻擦，然后抹干。请勿使用如汽油之类的溶剂。
- 3、清洁保养后一定要等到充分干燥后才能通电使用或收纳。
- 4、不用时请将电源线插头从电源插座上拔掉，加套薄膜袋放进机器背后的电源线收纳仓防尘。建议用原包装箱包好，收纳于干燥的地方。
- 5、长期不使用时请将水箱清洗干净。

注意：清洗维护前请务必拔掉插头，确保取暖器断电。

水箱清洁



① 可用干净的软湿布擦拭。

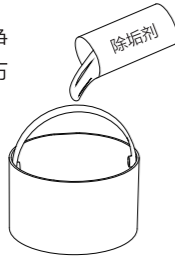

② 加入除垢剂或清水清洁，清洁后冲洗干净。

- 清洁前，请务必拔掉电源插头。
- 使用加湿功能必须定期清洗水箱内水垢和杂物，建议1-2周清理一次。
- 移动机器前需要把水箱里的水处理干净后再移动机器。
- 建议为保证清洁每天用新的纯净水更换水箱中的水。

过滤网拆装

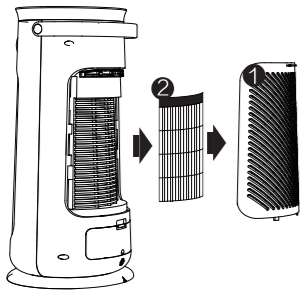

过滤网拆卸：

- 1、按着过滤网保护壳卡扣，小心打开保护壳；
- 2、拿出过滤网。

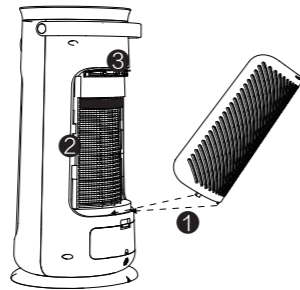

过滤网安装：

- 1、先安装下方卡扣；
- 2、按紧中部卡扣；
- 3、最后装好上部卡扣。

08 / 电气原理图

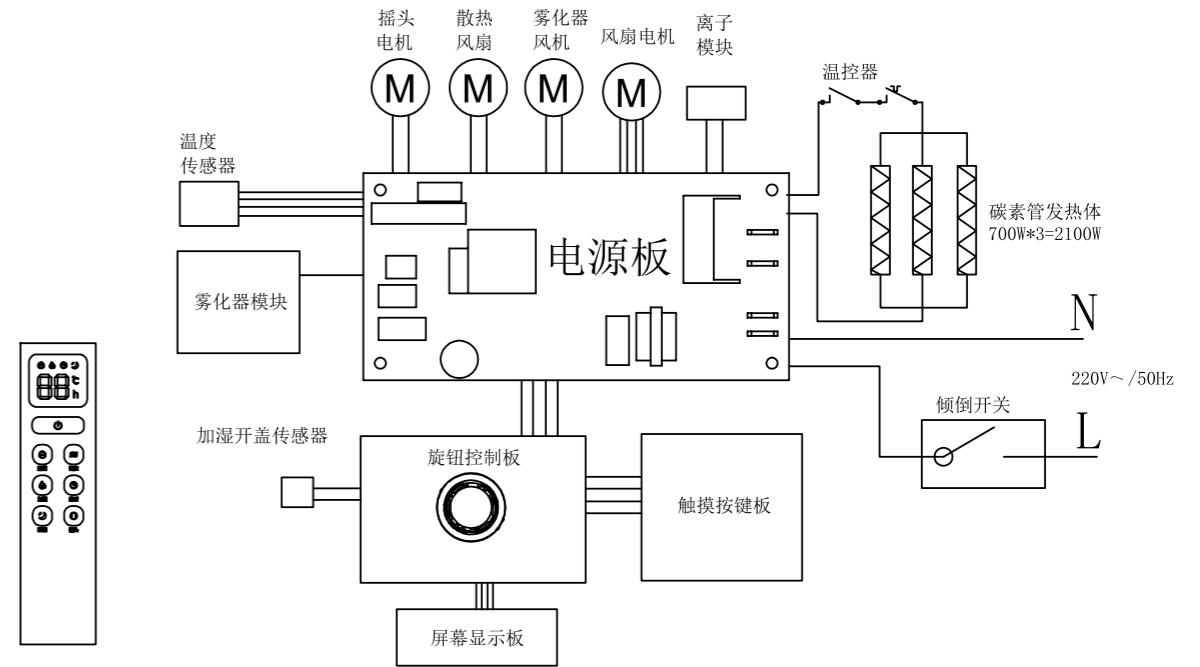

注意：电气原理图仅供参考，如有变动，恕不另行通知。

09 / 故障问题与分析

故障现象	可能原因	排除方法
不运行	插头没有插好	确认插头已完全插入插座
	待机状态下未解除童锁	长按电源键解除童锁再开机
	电源键未触按	轻触电源键
	机器倾倒保护装置启动	放在水平地方使用
不制热	内部限温器启动	关机冷却后重新开机
	产品处于“P0”档	轻触档位按键切换档位
加湿不出雾	水箱没水	先关机，往水箱加水后重启
	没有开启加湿功能	轻触操作面板的加湿键切换
	水箱盖子没放好	加足够水量，盖好水箱盖，再次开启加湿功能
	聚能环塑料件没有装到位置	确认聚能环装配到位，开启加湿功能
加湿有异味	水箱的水变脏了	更换纯净水或清洁水箱

*如经以上处理后，机器还不能正常工作，请与客户服务中心联系。

显示屏报警

- 1.如显示屏报警显示“E1”，导致整机不加热工作，可能原因：温度传感器异常；
- 2.如显示屏报警显示“E2”，导致整机不加热工作，可能原因：风机异常。

如出现以上两种情况，请联系经销商或者拨打客服热线安排处理。

10 / 环保清单

- 1.本产品满足《电器电子产品有害物质限制使用管理办法》的要求；
- 2.在环保使用期限内,消费者在正常使用过程中不会出现有害物质泄露、析出等影响消费者健康的问题,可以放心使用;
- 3.本公司产品环保使用期限为10年,只有在说明书所述的正常情况下使用本产品时,“环保使用期限”才有效。

部件名称	有毒有害物质或元素					
	铅(Pb)	汞(Hg)	镉(Cd)	六价铬(Cr(VI))	多溴联苯(PBB)	多溴二苯醚(PBED)
电源线	×	○	○	○	○	○
电器组件	○	○	○	○	○	○
发热组件	○	○	○	○	○	○
限温器及	×	○	○	○	○	○
控温组件	○	○	○	○	○	○
螺钉及垫圈	○	○	○	○	○	○
外壳组件	○	○	○	○	○	○
遥控器组件	○	○	○	○	○	○

本表格依据SJ/T 11364 的规定编制。

○表示该物质在该部件所有均质材料中的含量均在GB/T26572规定的限量要求以下。

×表示该有害物质至少在该部件的某一均质材料中的含量超出GB/T26572规定的限量要求。

*环保清单为总表数据，各产品包含部件有所不同，请选择阅读。



环保使用期限10年:

表示本产品中含有的有害物质不会发生外泄或突变，用户在产品说明书所述情况下正常使用本产品不会对环境造成严重污染或对其人身、财产造成严重损害的期限。

箭头循环标志:

表示本产品可回收利用。超过使用期限或经过维修无法正常工作后，不应被随意丢弃，请交由正规回收渠道以及有废弃电器电子产品处理资格的企业处理，正确的处理方法请查阅国家或当地有关旧电器电子产品的处理规定。

11 / 保修说明

1. 联系售后

说明退换货原因，达成退换货协议凡购买舒乐氏系列电器产品的用户，将根据国家有关部门规定《部分商品修理、更换、退货责任规定》享受全面“三包”服务。
(整机保修一年，电机保修三年)

2. 保修原则

- 1) 收到货次日起至7天内，享受七天无理由退换货服务；如因用户主观原因（非质量问题）导致的退换货，须由用户承担寄回运费；
- 2) 收货8-30天内,因质量问题导致产品无法正常使用，享受免费换新服务；
- 3) 本产品享受免费质保1年，1年内商品出现质量问题影响正常使用,可享受免费维修服务，且厂家承担维修后回寄费用；
- 4) 以下情况不享受退换货服务；
 - a、未填写售后服务保修卡，且配件不齐的商品（随商品赠送的赠品须一起寄回且产品无人为破损）；
 - b、产品出现人为破损，发票丢失等不享受无理由退换。

3. 保修方法:

- 1) 更换配件或享受免费维修服务时，须提供保修卡及购买凭证图片给在线客服；
- 2) 若出现质量问题，可拍图保留证据咨询在线客服或拨打商家400-8083-081服务热线提供售后指引。

12 / 保修卡

- ① 本产品实行整机保修，保修期为一年，起始日期自开具产品发票或购物凭证之日起计算，整机及主要零部件保修同国家三包政策。
- ② 在保修期内，凡属产品本身质量引起的性能故障，请顾客凭已填好的保修卡及购物凭证到指定维修点免费修理。
- ③ 请妥善保存购机发票或凭证。

以下情况恕不免费维修

- ① 放弃保修卡及有效发票或购物凭证。
- ② 发票型号与维修产品型号不符或者有涂改。
- ③ 未按说明书的要求操作机器所引起的故障。

产品信息:

产品名称	
产品型号	
购买日期	
购买地点	

维修记录:

维修日期	维修情况



SoleusAir Humidifier Heater

SLS-JQN1



The product picture shown is for reference only. The actual product may vary.

User Manual

Thank you for purchasing this product! Please read this manual carefully before using this product and keep it properly.

Implementation standards: GB 4706.1-2005, GB 4706.23-2007, GB 4343.1-2018, and GB 17625.1-2012

索力雅斯商务咨询（上海）有限公司（商标持有人）
佛山方信网络科技有限公司

售后服务热线：400-8083-081 官方网站：www.soleusair.com
制造商地址：广东省佛山市顺德区大良街道北区社区绿田路12号A栋3层304号

Thank you for choosing this product!

- Please read this manual carefully for proper use before using this product.
- Please keep this manual and the warranty card properly for future use.
- The product shall be subject to the actual object in the package.

Contents

Safety Precautions-----	1	Maintenance and Cleaning-----	7
Product Components-----	2	Electrical Schematic Diagram-----	8
Control Panel-----	3	Troubleshooting and Analysis-----	9
Technical Parameters-----	4	Environmental Protection List-----	10
Packing List-----	4	Warranty Notes-----	11
Functions and Operation Instructions-----	5-6	Warranty Card-----	12

01/Safety Precautions



Notes for Use

When using the humidifier heater for the first time, please let it work continuously for about two hours in a well-ventilated environment to remove the odor of the protective materials on the surface of the heating element. It is normal if there is a slight sound inside the product during the first use. When the humidifier heater is working, it should be placed in a well-ventilated environment.

01. Warning: Do not cover the heater, in order to avoid overheating.
02. Please check whether the voltage used is the same as that marked on the product before using this product.
03. Do not let the exposed skin approach or be in direct contact with the surface of the air outlet when using the product, in order to avoid burns.
04. The power cord should be placed behind the machine body when the product is in use. It will be overheated and damaged if being placed in front of the machine body, even causing a safety accident.
05. This product must not share a socket with other high-power electrical appliances and must not be used on a mobile socket. Its power cord must not be extended.
06. Do not move the product by directly pulling its power cord.
07. The heater must not be placed directly under the power socket.
08. Please check the power cord and the plug for damage before using this product.
09. This product is only suitable for indoor use, not for outdoor use.
10. Do not start or shut down the machine by plugging or unplugging its power cord.
11. When the product is in normal use or idle, it should be placed more than 1.5m away from any fire source or fire, and should be kept out of direct sunlight.
12. Do not use this product near objects that are flammable, explosive, or easily deformed, discolored or deteriorated by heat or in places with severe dust.
13. Please place this product stably when using it. Do not overturn or tilt it.
14. Do not use this product in places where there are hanging objects that are easy to fall or where the product is vulnerable to impact or unstable placement.
15. Do not use this heater around bathtubs, sprayers and swimming pools.
16. Do not immerse this product in water.
17. Do not insert thin metal wires or other foreign objects into any holes in the machine, in order to avoid electric shock accidents.
18. Do not use this product with a programmer, timer or other device that can automatically turn on the power supply.
19. In the event of any fault of the product, please shut it down and unplug it immediately, and contact the after-sales customer service promptly to arrange maintenance. Any non-professional or unauthorized repairmen are not allowed to repair or modify this product without permission.
20. Do not use this product as the warming or heating equipment for animals and plants.
21. Any damaged power cord must be replaced by professionals from the manufacturer, its maintenance department or similar departments, in order to avoid danger.
22. It is normal if there is a little peculiar smell when the new product is unpacked for the first time. It can greatly reduce the smell by placing the product in a ventilated environment for 4 hours.
23. Do not remove the water tank or directly feel the water temperature with your hands during the operation of the product, in order to avoid accidents.
24. Do not place any items on top of the product or climb or sit on the machine.
25. If it is necessary to remove the upper cover, water tank or other components in order to clean the product, please install them correctly in sequence after cleaning. If these components are not installed properly, it may affect the normal use of the product.
26. Please fully insert the power cord plug into the power socket before using this product each time, in order to avoid abnormal heating or even fire caused by poor contact between the plug and the socket.
27. In the event of damage to the glass cover of the product's heating tube, please stop using the product immediately and contact the after-sales customer service promptly.
28. Please shut down this product and unplug it before cleaning or performing other maintenance operations on it.
29. Do not allow children and persons who have behavioral impairments to operate or use this product alone, and do not allow them to approach or touch the heating surface when this product is in use, in order to avoid accidents.

02/Product Components

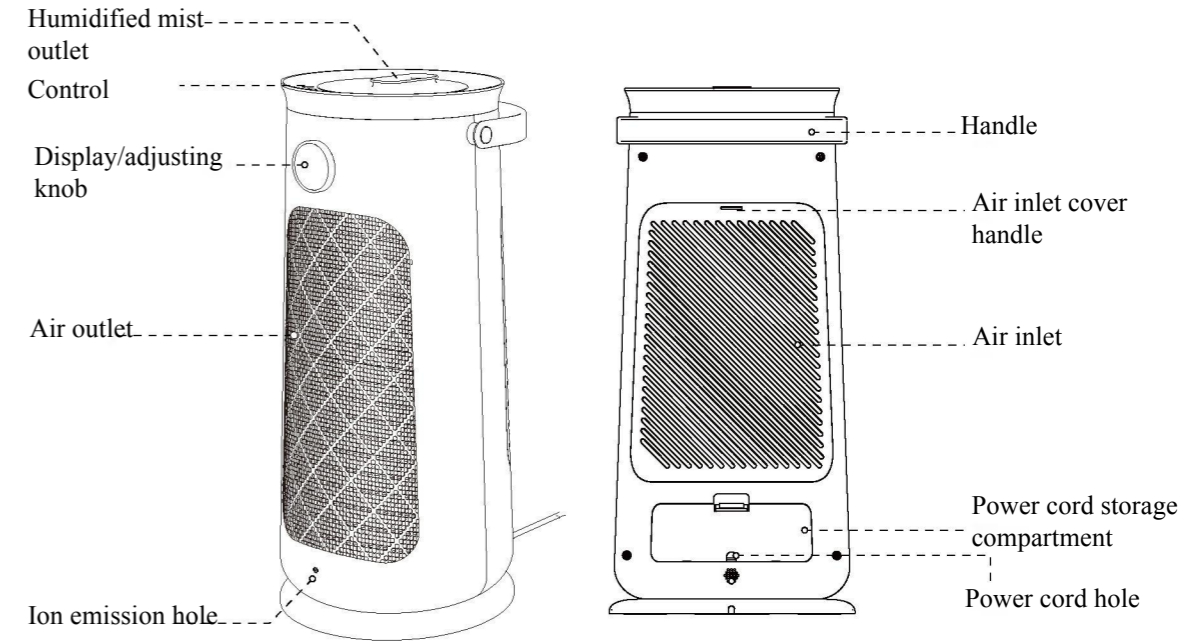

- Due to the continuous improvement of our products, the product you purchased may differ from that shown in the manual. In such cases, there will be no further notice. Please refer to the actual product.

03/Control Panel

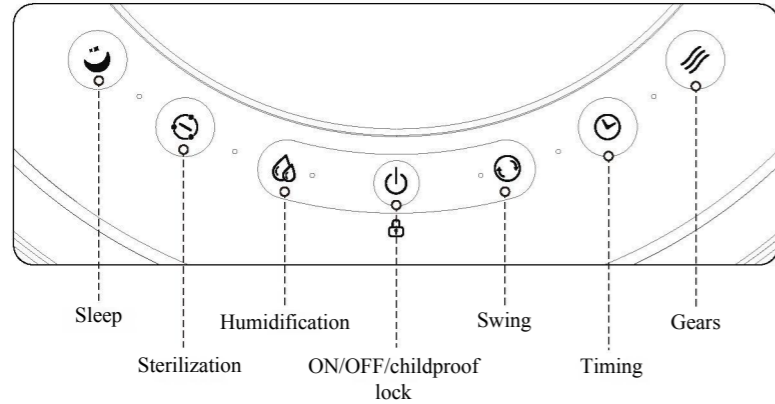

Display interface

Counterclockwise:
Down

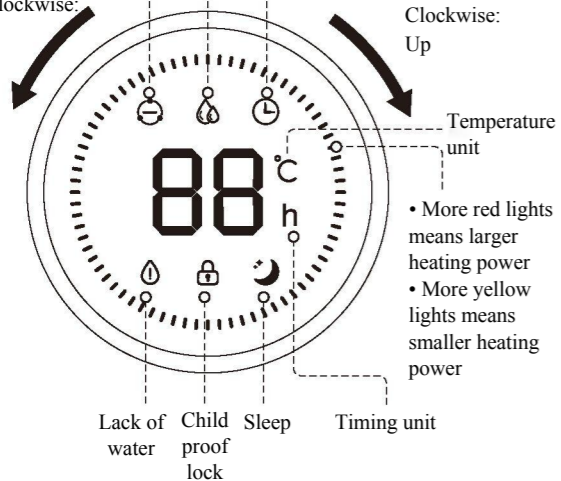

* At Gears P1 - P5, the heating effect can be adjusted by turning the knob. Under normal conditions, temperature and gears are displayed alternately.

Remote control

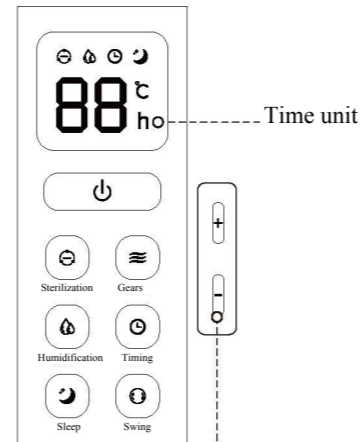

- Set timer
 - Adjust heating effect
- The display of the remote control does not change during adjustment.

* Operation of buttons on the remote control is the same as that of the buttons on the machine body.

04/Technical Parameters

Product name	Humidifier heater	Product model	SLS-JQN1
Rated voltage	220V ~	Rated power	2100W
Product dimensions	305 × 305 × 654mm	Rated frequency	50Hz
Water tank capacity	2.0L	Net weight	7.9kg
Implementation standards	GB 4706.1-2005 GB 4706.23-2007 GB 4343.1-2018 GB 17625.1-2012		







* The above parameters are design parameters, and the measured parameters are subject to the actual product.

05/Packing List





S/N	Component Name	Quantity
01	Main unit	1
02	Remote control	1
03	Filter screen	1
04	User manual	1
05	Remote control battery (AAA battery)	2

* Please remove the film when using the filter screen for the first time.

06/Functions and Operation Instructions

<p>ON/OFF /childproof lock</p> 	<ul style="list-style-type: none"> After the machine is powered on, the buzzer will prompt, "ON/OFF" will turn red, and the product will enter the standby state. Tap "ON/OFF". The machine will start, "ON/OFF" will turn white, and the default gear will be P0. After the machine starts working, you can press "Gears" to switch among Gears P1 - P5 for heating. At this time, you can enable the sleep, sterilization, humidification, swing, and timing functions. Tap "ON/OFF" when the machine is working. The machine will stop heating and enter the standby state, and the fan will continue to run for a certain time for heat dissipation before stopping. Start the machine again. The machine will automatically restore to the working setting state before shutdown. Press and hold "ON/OFF" when the machine is in standby or working state. The childproof lock will be enabled to prevent false triggering of startup. In the childproof lock state, other buttons and knobs will be invalid and can be operated only after unlocking. In the childproof lock state, you can use the remote control for startup/standby and other operations.
<p>Sleep</p> 	<ul style="list-style-type: none"> Tap "Sleep" and the machine will enter the sleep mode, and the default gear will be P1. In sleep mode, the display will be off and only the sleep icon will be displayed. You can tap any button to wake up the display for normal operation. In sleep mode, you can press "Gears" to adjust the gear or turn the knob to adjust the heating effect. Tap "Sleep" again. The sleep mode will exit.
<p>Sterilization</p> 	<ul style="list-style-type: none"> Tap "Sterilization" and the sterilization function will be enabled, and the function light will be on. Tap "Sterilization" again and the sterilization function will be disabled, and the function light will be off.
<p>Humidification</p> 	<ul style="list-style-type: none"> Tap "Humidification" and the atomization and humidification function will be enabled, and the function light will be on. Tap "Humidification" again and the atomization and humidification function will be disabled, and the function light will be off.
<p>Swing</p> 	<ul style="list-style-type: none"> Tap "Swing" and the swing function will be enabled, and the function light will be on. Tap "Swing" again to stop oscillating, and the function light will be off.
<p>Timing</p> 	<ul style="list-style-type: none"> Tap "Timing" to set the scheduled stop. Turn the knob or press "Timing" to set the time range from 0 to 12h. Enable the scheduled stop, and the function light will be on. Press and hold "Timing" to cancel the scheduled stop, and the function light will be off.

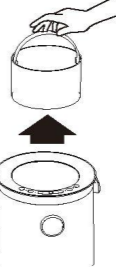
Functions and Operation Instructions

<p>Gears </p>	<ul style="list-style-type: none"> Tap "Gears" to cyclically switch from P0-P5. P1-P5 provides different hot air effects, and the heating effect is strengthened as the gear number rises. The hot air effect is not started at P0, which can be used with the atomization and humidification function. 	<p>Adjust the knob or press the "+" and "-" on the remote control</p>	<ul style="list-style-type: none"> Adjust the heating effect of the machine finely without changing the set gears and air speed of the machine. During adjustment, the display effect of the outer ring of the display screen will change accordingly.
<p>Add water</p> 	<p>1. Turn off the machine and pick up its top cover.</p>		<p>2. Take out the water tank.</p>
	<p>3. Add an appropriate amount of purified water (temperature: lower than 40 ° C) into the water tank.</p>		<p>4. After assembling the water tank and the top cover in sequence, power on the machine and enable the humidification function.</p>

- Be sure to unplug the machine before adding water.
- Please be careful when adding water. Do not add water into the mist outlet.

- The water level must not exceed the upper limit.
- Do not add additives such as essential oils, perfumes, drugs and other chemicals to the water.

07/Maintenance and Cleaning

1. Before cleaning and maintenance, be sure to unplug the power cord, disconnect the power supply, and cool the machine for 10 minutes.
2. Do not rinse the machine body with water. Wipe it gently with a soft cloth containing a little neutral detergent and then dry it. Do not use solvents such as gasoline.
3. After cleaning and maintenance, be sure to wait until it is fully dry before power-on for use or storage.
4. When the machine is not used, please unplug the power cord plug and put it into the power cord storage compartment behind with a bag film to prevent dust. It is recommended to pack it in the original packing box and store it in a dry place.
5. Please clean the water tank when the machine is not used for a long time.

Note: Before cleaning and maintenance, pull out the plug and power off the heater.

Water tank cleaning



1. Wipe with a clean soft wet cloth.



2. Add disinfectant or clean water for cleaning, and rinse it after cleaning.

- Always pull out the power plug before cleaning.
- Clear the scale and foreign matters in the water tank 1-2 weeks when the humidification function is enabled
- Before moving the machine, ensure that there is no water inside.
- It is recommended to replace the water in the water tank with new purified water every day to ensure cleanliness.

Filter screen removal & installation

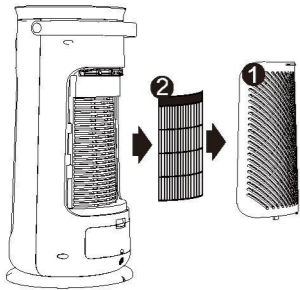

- Filter screen removal:
1. Press the clip of the filter screen protection cover and open it carefully.
 2. Take out the filter screen.

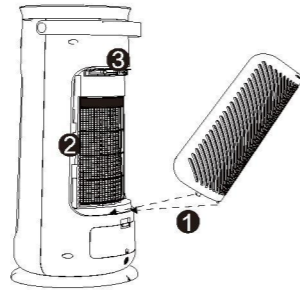

- Filter screen installation:
1. Install the lower clip first.
 2. Press the middle clip tightly.
 3. Install the upper clip.

08/Electrical Schematic Diagram

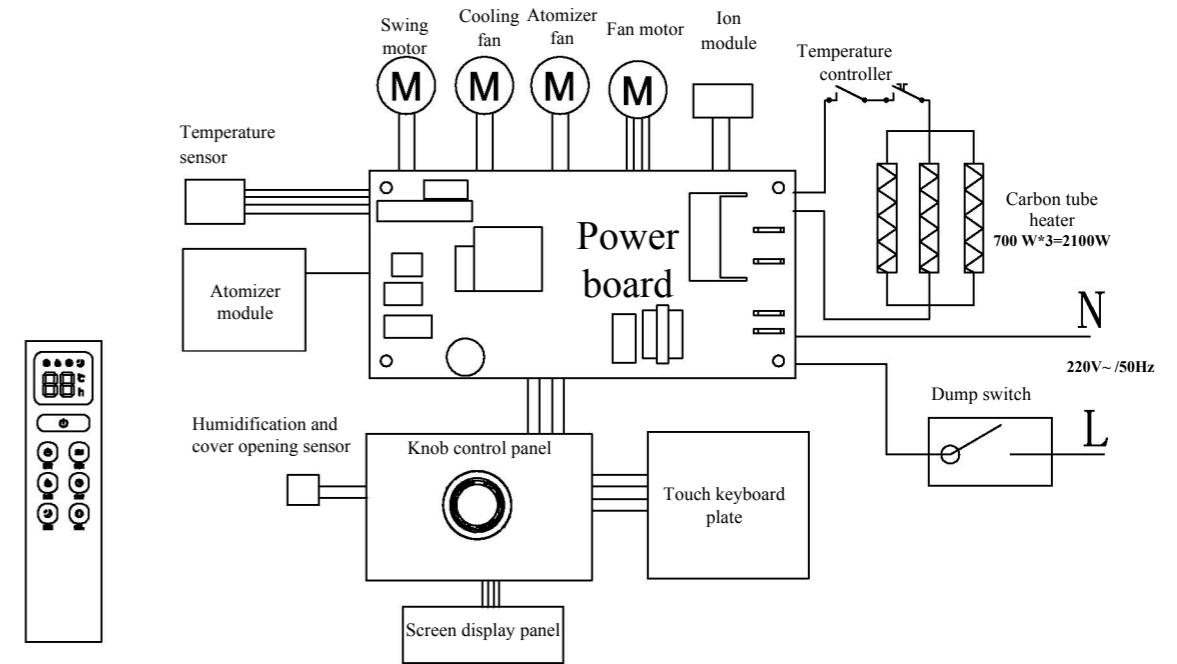

Note: The electrical schematic diagram is for reference only and is subject to change without notice.

09/Troubleshooting and Analysis

Fault	Possible Causes	Troubleshooting
Running failure	The power plug is not plugged in properly	Confirm that the plug is fully inserted into the socket
	Child safety lock is not unlocked in standby state	Press and hold "Power" to unlock the child safety lock before power connection
	"Power" is not pressed	Tap "Power"
	Machine tipping protection activated	Use it in a horizontal place
Heating failure	Internal temperature limiter starts	Restart after shutdown and cooling
	The product is at "P0"	Tap "Gears" to switch Gears
Humidification works without mist	There is no water in the water tank	Shut down first, add water to the water tank and restart
	The humidification function is not enabled	Touch "Humidification" on the operation panel for switching
	The water tank cover is not properly placed	Add enough water, cover the water tank, and enable the humidification function again
	The inner plastic ring is not installed in place	Confirm that the plastic ring is assembled in place and enable the humidification function
Humidification works with peculiar smell	The water in the water tank is dirty	Replace purified water or clean the water tank

* If the machine still fails to work normally after the steps above, please contact the customer service center.

Display screen alarm

- The temperature sensor may fail if the display screen shows "E1" for alarm, and the heating function of whole machine does not work.
- The fan may fail if the display screen shows "E2" for alarm, and the whole machine does not work.

In case of the above two situations, please contact the dealer or call the customer service hotline.

10/Environmental Protection List

- This product meets the requirements of the *Administrative Measures for the Restriction of the Use of Hazardous Substances in Electrical and Electronic Products*.
- During the environmental protection use period, consumers can use the product at ease without any leakage or precipitation of harmful substances that may affect their health during normal use.
- The environmental protection use period of our products is 10 years and is valid only when this product is used under the normal conditions described in this manual.

Component Name	Toxic and Hazardous Substances or Elements					
	Lead (Pb)	Mercury (Hg)	Cadmium (Cd)	Hexavalent chromium (Cr(VI))	Polybrominated biphenyls (PBB)	Polybrominated diphenyl ethers (PBED)
Power cord	×	○	○	○	○	○
Electrical component	○	○	○	○	○	○
Heating component	○	○	○	○	○	○
Temperature limiter	×	○	○	○	○	○
Temperature control component	○	○	○	○	○	○
Screw and washer	○	○	○	○	○	○
Enclosure assembly	○	○	○	○	○	○
Remote control assembly	○	○	○	○	○	○

This table is prepared in accordance with SJ/T 11364.

"○" indicates that the content of the substance in all homogeneous materials of the component is below the limit specified in GB/T26572.

"×" indicates that the content of the hazardous substance in at least one homogeneous material of the component exceeds the limit specified in GB/T26572.

* The environmental protection list provides the data of the summary table, and the components contained in each product are different. Please read it as needed.

Environmental protection use period: 10 years;

It refers to the period during which the hazardous substances contained in this product will not leak or mutate suddenly and will not result in serious environmental pollution or cause serious bodily injury to users or damage to their assets during the normal use under the conditions described in the product manual.



Arrow circle:

It indicates that the product is recyclable. After the service life expires or the equipment cannot work normally after maintenance, it shall not be discarded at will. In this case, please hand it over to formal recycling channels and enterprises with disposal qualification for waste electrical and electronic products. For the correct disposal methods, please refer to the national or local regulations on the disposal of used electrical and electronic products.

11/Warranty Notes

1. After-sales service

Reasons should be explained for return or replacement before an agreement on return or replacement is reached. Customers who bought SoleusAir electrical products will enjoy the comprehensive "three guarantees" service according to the *Provisions on the Liability for the Repair, Replacement and Return of Some Commodities* stipulated by relevant national departments.

(One-year warranty for complete machine and three-year warranty for motor)

2. Warranty principles

- 1) Within 7 days from the day after receiving the commodity, a user enjoys a 7-day no-questions-asked return and replacement service. If the commodity is returned or replaced due to the subjective reasons of the user (other than quality problems), the user must bear the return freight.
- 2) Within 8-30 days after receiving the commodity, if the product cannot be used normally due to quality problems, it can be replaced free of charge.
- 3) This warranty period of the product is 1 year. In case of quality problems affecting the normal use of the product within 1 year, it can be repaired free of charge, and the manufacturer will bear the return freight after the repair.
- 4) Return and replacement services are not available under the following circumstances.
 - a. The commodity without after-sales service warranty card and with incomplete accessories (the gifts provided with the commodity must be sent back together without artificial damage).
 - b. No-questions-asked return and replacement is not allowed if the product is artificially damaged or the invoice is lost.

3. Warranty method:

- 1) When replacing accessories or enjoying free maintenance service, please send the pictures of the warranty card and purchase certificate to our online customer service.
- 2) If there is a quality problem, take pictures to keep evidence and consult our online customer service or call the service hotline of the merchant 400-8083-081 for after-sales guidance.

12/Warranty Card

- ① The warranty period of the complete machine is one year, starting from the date of issuing the product invoice or purchase voucher. The warranty of the complete machine and main parts is subject to the national warranty policy.
- ② During the warranty period, for any performance failure caused by the quality of the product itself, please go to the designated maintenance point for free repair with the filled warranty card and shopping receipt.
- ③ Please keep the purchase invoice or shopping receipt properly.

Repair is not free of charge in the following cases

- ① The warranty card and valid invoice or shopping receipt are waived.
- ② The model on the invoice is inconsistent with that of the product to be repaired or has been altered.
- ③ The faults are caused by failure to operate the machine according to the requirements of the manual.

Product information:

Repair record (s):

Product information:		Repair record (s):	
Product name		Repair date	Repair details
Product model			
Purchased on			
Purchased at			